



SENSORY ANALYSIS OF OLIVE OIL

STANDARD

GUIDE FOR THE INSTALLATION OF A TEST ROOM

1. INTRODUCTION

The test room is designed to provide the panel participating in the sensory tests with a suitable, comfortable, standardised environment which facilitates work and helps to improve the repeatability and reproducibility of the results.

2. PURPOSE

The purpose of this standard is to specify the basic conditions that have to be met when installing a test room.

3. GENERAL SPECIFICATIONS FOR INSTALLATION

The premises, however large they are, shall meet the following specifications:

They shall be pleasant and suitably lighted but neutral in style. For this purpose, a soothing, plain, light colour is recommended for the walls so that a relaxed atmosphere is created ^{1/}.

The premises shall be such that they are easily cleaned and shall be separated from any source of noise; consequently, they shall preferably be sound proofed. They shall also be kept free from extraneous odours for which purpose, if possible, they shall be fitted with an effective ventilation device. If the fluctuations in ambient temperature so warrant, the test room shall be equipped with air conditioning to keep the atmosphere close to 20-22° C.

^{1/} The colour scheme of the room and its lighting can affect the results of the sensory analysis.

3.1. Dimensions

The dimensions of the premises often depend upon the possibilities of the laboratories or companies. Generally, they should be sufficiently spacious to permit the installation of ten booths and an area for preparing the samples.

However, it is obvious that the larger the area set aside for the installations, the better, since auxiliary areas can then be provided, for instance, for cleaning apparatus, arranging food preparations and assembling open panels.

3.2. Lighting

General lighting, whether from sunlight or lamps (for instance, strip lighting) shall be uniform, controllable and diffuse.

3.3. Temperature and hygrometric conditions

The premises shall be kept constantly at a pleasant temperature and under agreeable hygrometric conditions. Except in special circumstances, a temperature of 20 ° - 22 ° C and hygrometric conditions of 60 to 70% relative humidity are recommended.

4. DESCRIPTION OF BOOTHS

4.1. General characteristics

The sensory analysis booths shall be placed alongside each other in the premises. They shall be identical and shall be separated by partitions which shall be sufficiently high and wide as to isolate the tasters when seated.

The booths may be made of any appropriate material which is easily cleaned and looked after (for instance, wood, vitrified plywood, laminated panelling, etc). If paint is used, it must be completely odour-free when dry.

The seats provided in the booths shall be comfortable and shall have an adjustable height device.

Each booth shall also be provided with individual lighting, the direction and intensity of which may be adjusted.

It is highly recommended that the booths be equipped with a button connected to an outside light which enables the taster to make known to the attendant outside that he has finished the test, requires further samples, is missing a piece of apparatus, has noticed some irregularity, or wishes information, etc. without distracting the other tasters.

4.2. Dimensions

The booths shall be sufficiently large and comfortable. In general, they shall have the following dimensions:

Width: 0.75 m (without sink)
 0.85 m (with sink)

Length: 0.50 m (table)
 0.20 m excess for partition

Height of partitions:

 0.60 m minimum from table

Height of table:

 0.75 m.

4.3. Arrangement

The table surface shall be such that it is easily cleaned.

Part of this surface shall be used for a sink provided with running, drinking water. However, if this is not practicable, this space may be used for a tray, spittoon or similar piece of equipment.

When the samples have to be kept during the test at a constant temperature that is above or below ambient temperature, it is advisable to have a suitable device for this purpose (bain-marie, hot plate, etc.).

A shelf may also be set up at a height of approximately 1.10 metres from the floor for placing various accessories (glasses, small apparatus, etc.).

If the arrangement of the booths in the test room so permits, it is worthwhile installing a device to facilitate the presentation of the samples. This may be in the form of a sliding hatch (Figure 1), a revolving vertical device (Figure 2) suitable for glasses or cups (tall containers), or a horizontally-opening hatch when the containers in which the samples are kept are small (Figure 3). It is simply a question of ensuring that the opening is large enough for the trays and glasses containing the samples to pass through.

5. ADDITIONAL PREMISES

If there is sufficient space, it is advisable to provide separate premises for preparing the samples (test kitchen if culinary or other tests are planned), shelves for arranging glasses or apparatus and rooms for holding discussions prior to or after the tests. If available, such premises shall be kept clean; in no way shall any smells, noise or conversations from these premises disturb the work of the assessors in the test room.

See Figure 4 for an example of a test room and additional premises.

Notes:

Ideal conditions are described. However, if it were not possible to have such an installation solely for sensory analyses, the tests could be performed in premises that meet the minimum conditions described (lighting, temperature, noise, odours) by setting up mobile booths made up of folding elements in such a way that, at the very least, they isolate the tasters from each other.

Fig. 1

ARRANGEMENT OF THE BOOTH

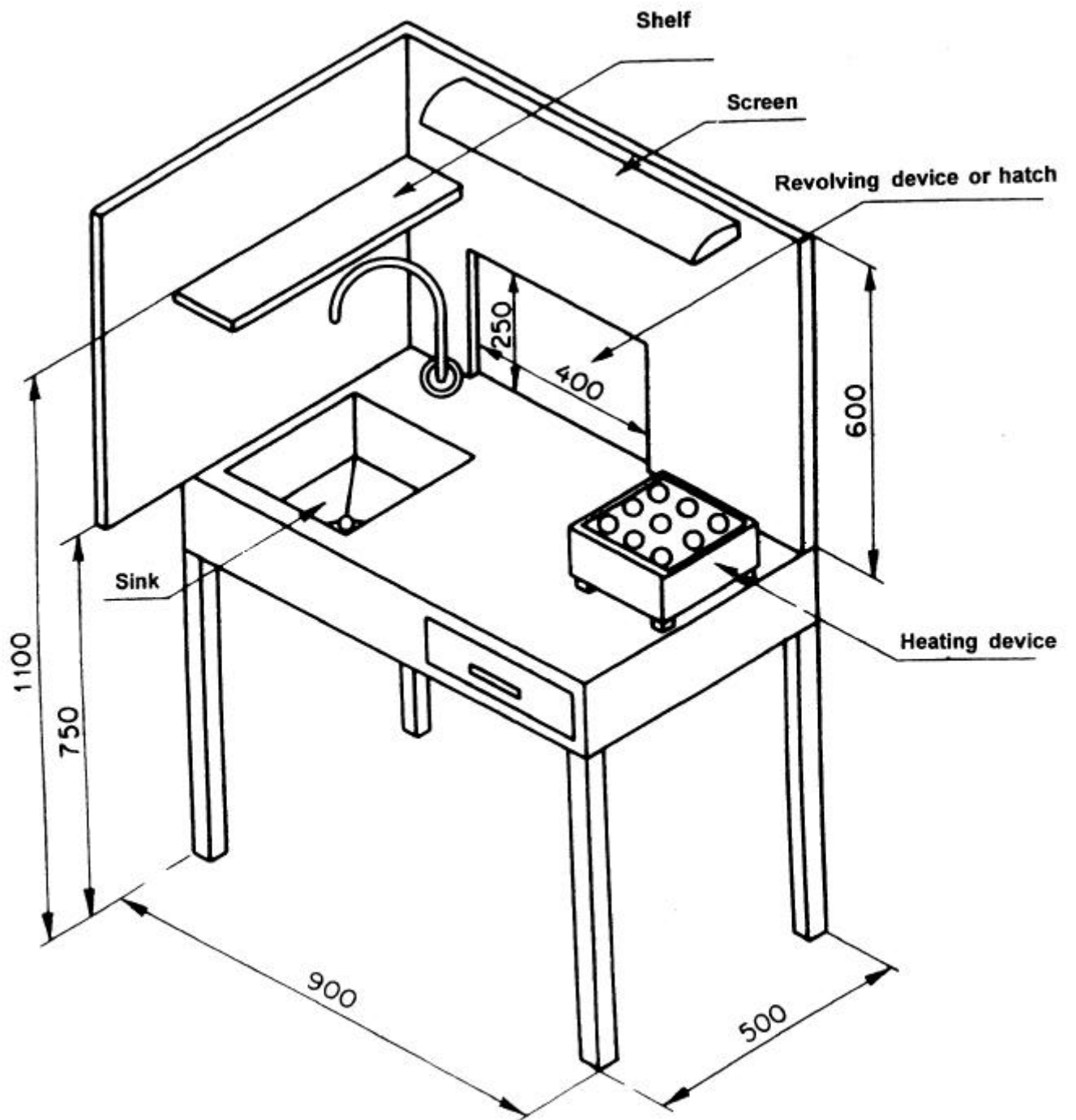

Fig. 2

**REVOLVING DEVICE FOR
PRESENTING SAMPLES**

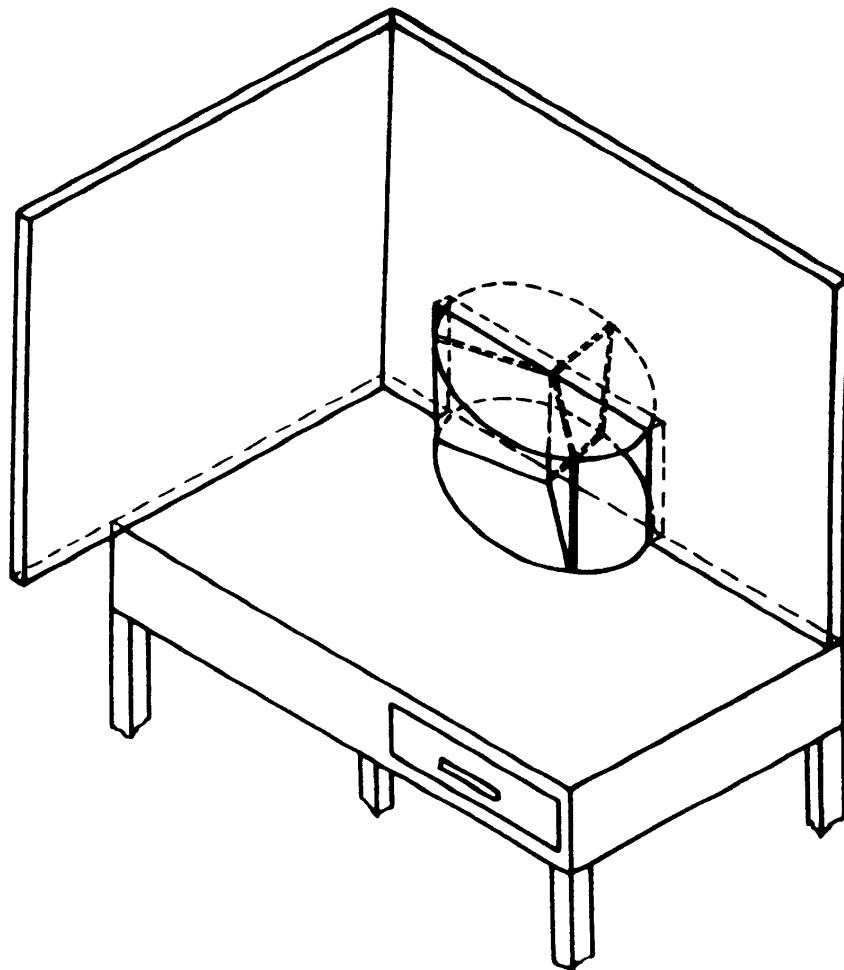

Fig. 3

HATCH FOR PRESENTING SAMPLES

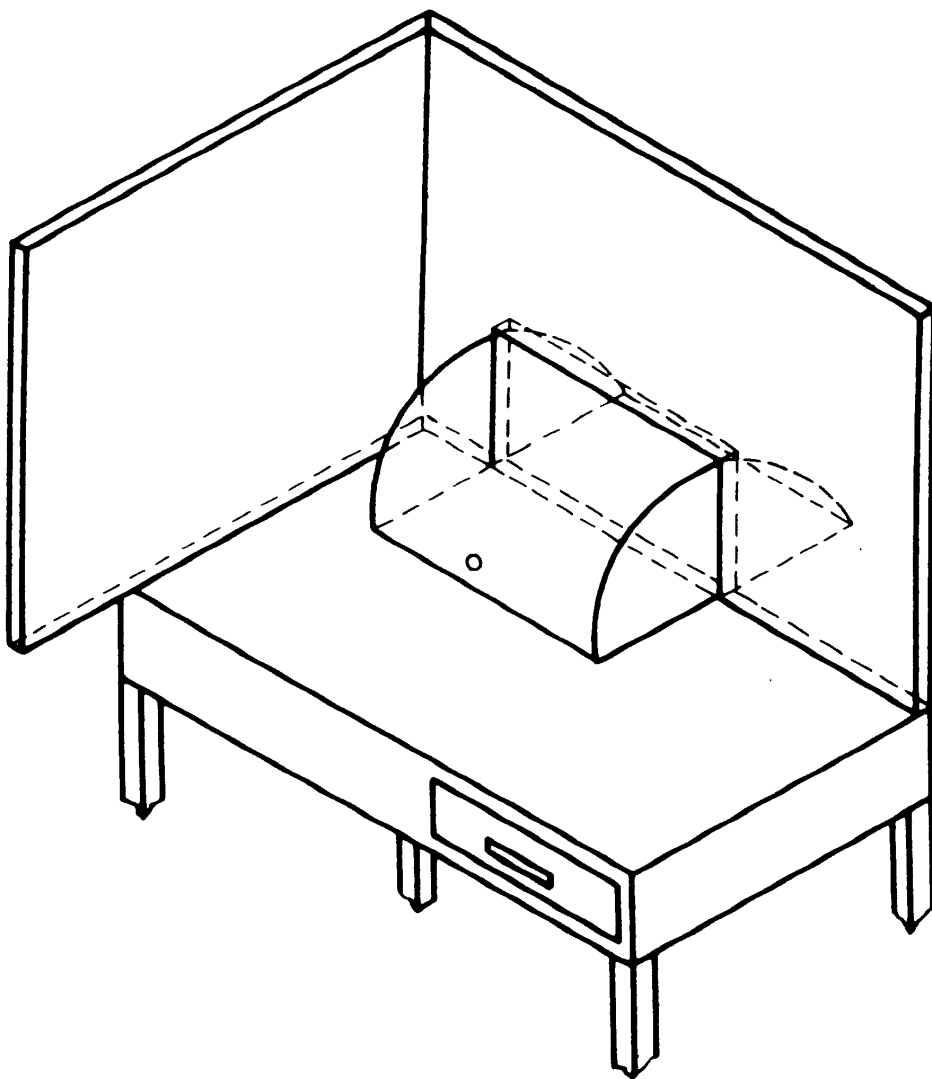
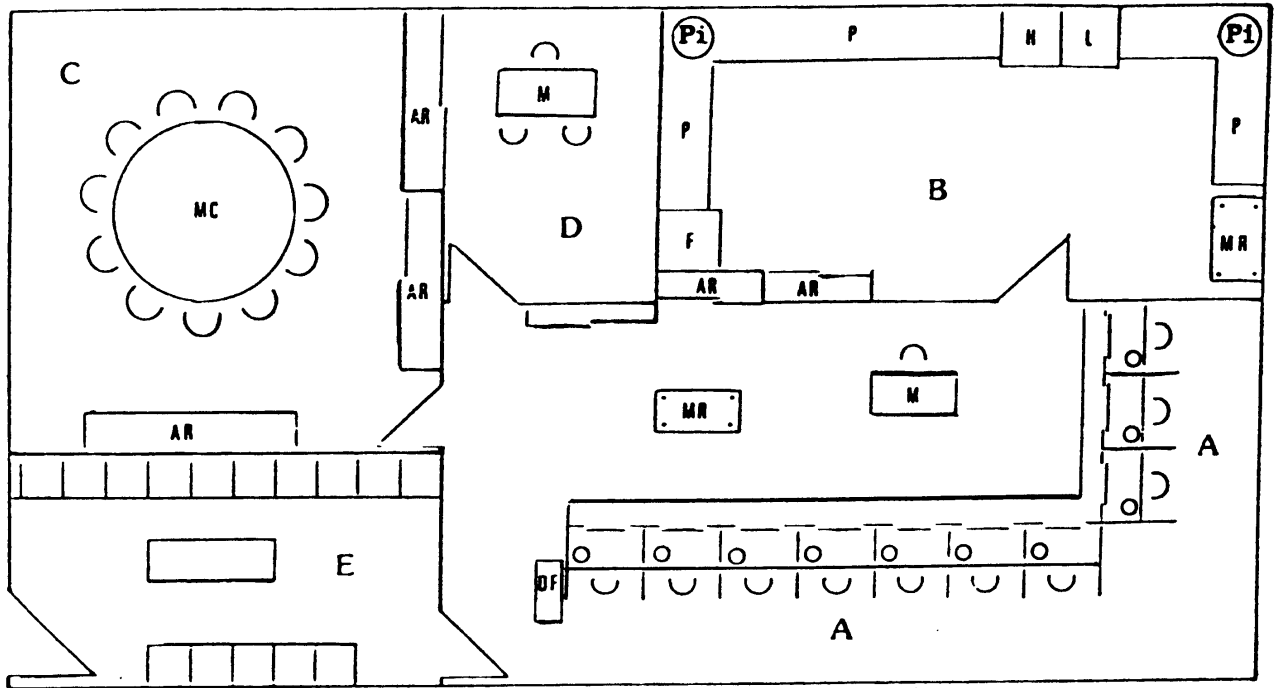

Fig. 4

EXAMPLE OF A TEST ROOM



- A - Tasting booths.
- B - Room for cleaning apparatus and preparing samples
- C - Open panel
- D - Office
- E - Waiting room
- F - Refrigerator
- H - Oven
- L - Dishwasher
- M - Table
- P - Work surface
- Pi - Sink
- Ar - Cupboard
- Mr - Trolley
- Df - Distribution of forms
- Mc - Round table

