



**INTERNATIONAL  
OLIVE OIL  
COUNCIL**

COI/T.20/Doc.no.5  
18 June 1987  
ENGLISH  
Original: SPANISH

Príncipe de Vergara, 154 – 28002 Madrid – España Telef.: +34 915 903 638 Fax: +34 915 631 263 - e-mail: [ioc@internationaloliveoil.org](mailto:ioc@internationaloliveoil.org) - <http://www.internationaloliveoil.org/>

---

**SENSORY ANALYSIS OF OLIVE OIL**

**STANDARD**

**GLASS FOR OIL TASTING**

**1. PURPOSE**

The purpose of this standard is to describe the characteristics of the glass intended for use in the organoleptic analysis of edible oils (odour, taste, flavour).

In addition, it describes the adapted heating unit needed to reach and maintain the right temperature for this analysis.

**2. DESCRIPTION OF THE GLASS**

The drawing in Figure 1 attempts to establish the optimum characteristics desirable in a piece of apparatus of this kind, which can be specified as follows:

- a) Maximum steadiness, to prevent the glass from tilting and the oil from being spilled.
- b) A base which easily fits the indentations of the heating unit so that the bottom of the glass is evenly heated.
- c) A narrow mouth which helps to concentrate the odours and facilitates their identification.
- d) Made of dark-coloured glass to prevent the taster from perceiving the colour of the oil, thus eliminating any prejudices and impeding the possible formation of biases or tendencies that might affect the objectiveness of the determination.

## 2.1. **Dimensions**

The glass is sketched in Figure 1, and has the following dimensions:

|                                      |                     |
|--------------------------------------|---------------------|
| Total capacity.....                  | 130 ml $\pm$ 10 ml  |
| Total height.....                    | 60 mm $\pm$ 1 mm    |
| Diameter of mouth .....              | 50 mm $\pm$ 1 mm    |
| Diameter of glass at its widest..... | 70 mm $\pm$ 1 mm    |
| Base diameter.....                   | 35 mm $\pm$ 1 mm    |
| Thickness of glass on sides.....     | 1.5 mm $\pm$ 0.2 mm |
| Thickness of glass base .....        | 5 mm $\pm$ 1 mm     |

Each glass shall be equipped with a watch-glass, the diameter of which shall be 10 mm larger than the mouth of the glass. This watch-glass shall be used as a cover to prevent the loss of aroma and the entry of dust.

## 2.2. **Manufacturing characteristics**

The glass shall be made of resistant glass; it shall be dark-coloured so that the colour of its contents cannot be discerned, and shall be free from scratches or bubbles.

The rim shall be even, smooth and flanged.

The glass shall be annealed so that it stands the temperature changes it has to undergo in the tests.

## 2.3. **Instructions for use**

The glasses shall be cleaned using unperfumed soap or detergent and shall then be rinsed repeatedly until the cleaning agent has been totally eliminated. The final rinse shall be with distilled water, after which the glasses shall be left to drain and then dried in a desiccation stove.

Neither concentrated acids nor chromic acid mixtures shall be used.

The glasses shall be kept in the stove until required for use or shall be kept in a cupboard in which they shall be protected from contamination from any extraneous odours.

Before use, each glass shall be smelled to ensure that no extraneous odour is present. When the test is being prepared care shall be taken to record the code of each glass and the oil it contains. The panel supervisor shall be the only person to know this code/oil relation.

### **3. DEVICE FOR HEATING SAMPLES**

The samples shall be organoleptically examined at a set temperature which, in the case of edible oils, shall be  $28 \pm 2^{\circ}\text{C}$ . For this purpose, a heating device (see Figure 2) shall be installed in each booth within the taster's reach. It comprises an aluminium block immersed in a thermostatically-controlled water bath so as to keep a uniform temperature. This block has a series of indentations into which fit the bottoms of the glasses. The temperature difference between the heating device and the oil contained in the glasses inserted in the indentations of the various blocks shall not be more than  $\pm 2^{\circ}\text{C}$ .

Fig. 1

**TASTING GLASS**

(dimensions in millimetres)

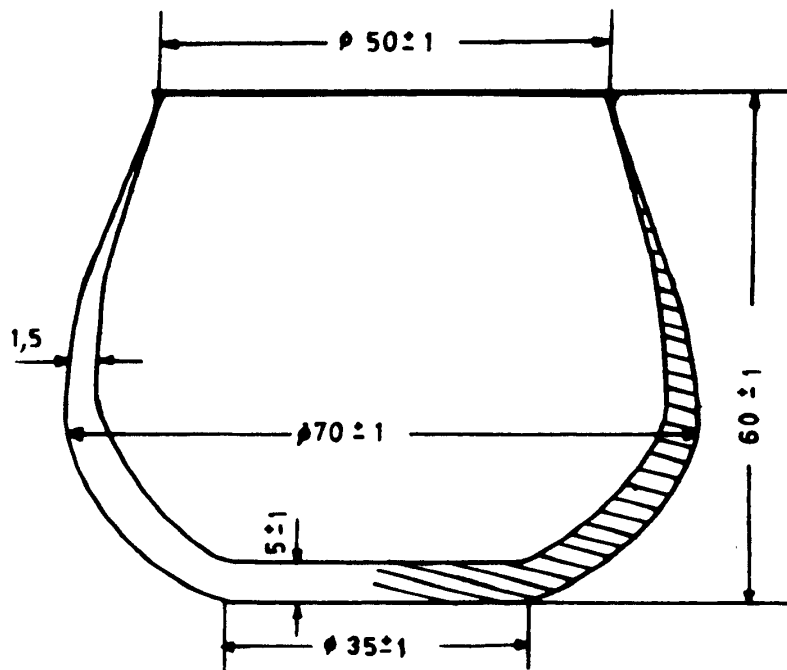

Fig. 2

**DEVICE FOR HEATING SAMPLES**

(dimensions in millimetres)

